

# Maxi-CUBE

## Slide-A-Side

Chiller & Dry Freight



## The Maxi-CUBE Slide-A-Side

The original hard wall, side loading van, provides fast loading and unloading with increased van security and payload retention. For 30 years, Maxi-CUBE has lead the Australian temperature controlled transport market in product innovation.

### Some Maxi-CUBE Options to suit your needs

- Various lengths and heights available to order
- Disc brakes
- Airflow / anti-slip floor/flat aluminium floor
- Fibreglass rear infill panel
- Roller rear door

\*Photo for illustrative purposes only.

# Slide-A-Side Specifications

(Nominal and Typical)

## Dimensions

Length	13540mm (Nominal)
Overall Height	4300mm
Aperture Height	2725mm (flush floor)
Rear Door Opening	H-2600mm W-2400mm
Internal Length	13215mm
Skidplate Height	1270mm
Kingpin Location	1240mm/1300mm from front
Suspension Location	Up to 9500mm from kingpin

## Body

Side Walls	Sliding both sides, 25mm fiberglass / urethane foam laminate
Front Wall	Dry Freight: FRP panel Chiller: fiberglass / urethane foam laminate
Rear Doors	FRP/ply panels with double lock rods and anti-rack
Roof	Dry Freight: aluminium sheet with aluminium roof bows Chiller: fiberglass / urethane foam laminate
Rub Strip	Internal - 300mm high fiberglass pultrusion
Rear Frame	Fabricated steel
Floor	Dry Freight: chequerplate steel Chiller: chequerplate steel with urethane foam insulation

## Frame

Bumper	Square
Skidplate	8mm with 50mm bolt-in kingpin
Base Frame	1040mm mainrail centres 12mm top flange 16mm bottom flange
Coaming	200mm pressed steel

## Brakes

S' Cam to A.D.R. 38. HXS Linings
Male and female couplings at front

## Underbody

Toolbox	1 standard - Kerbside
Tyre Carrier	1 standard - 2 Wheel

## Load Restraint (optional extra)

Loadlok Track	F Series-3 rows full length in floor and roof
Loadlok Bars	3 per unit

## Electrical

Voltage	Multi-volt (exterior lighting)
Lamps	LED to ADR 13
Couplings	Standard and heavy duty 7 pin

## Landing Gear

Rocker Foot	2 speed
-------------	---------

## Paint

1 Colour 2K Coatings, toolbox & hubs
Underside Silver
Unit Finish Exterior - White/Interior - Blue

## Mudguards

Extruded aluminium splashguards with sprayguard flaps fitted to rear of suspension group
--

## Suspension

Tri-axle air bag.
-------------------

## Axles

Maxus 10 stud
---------------

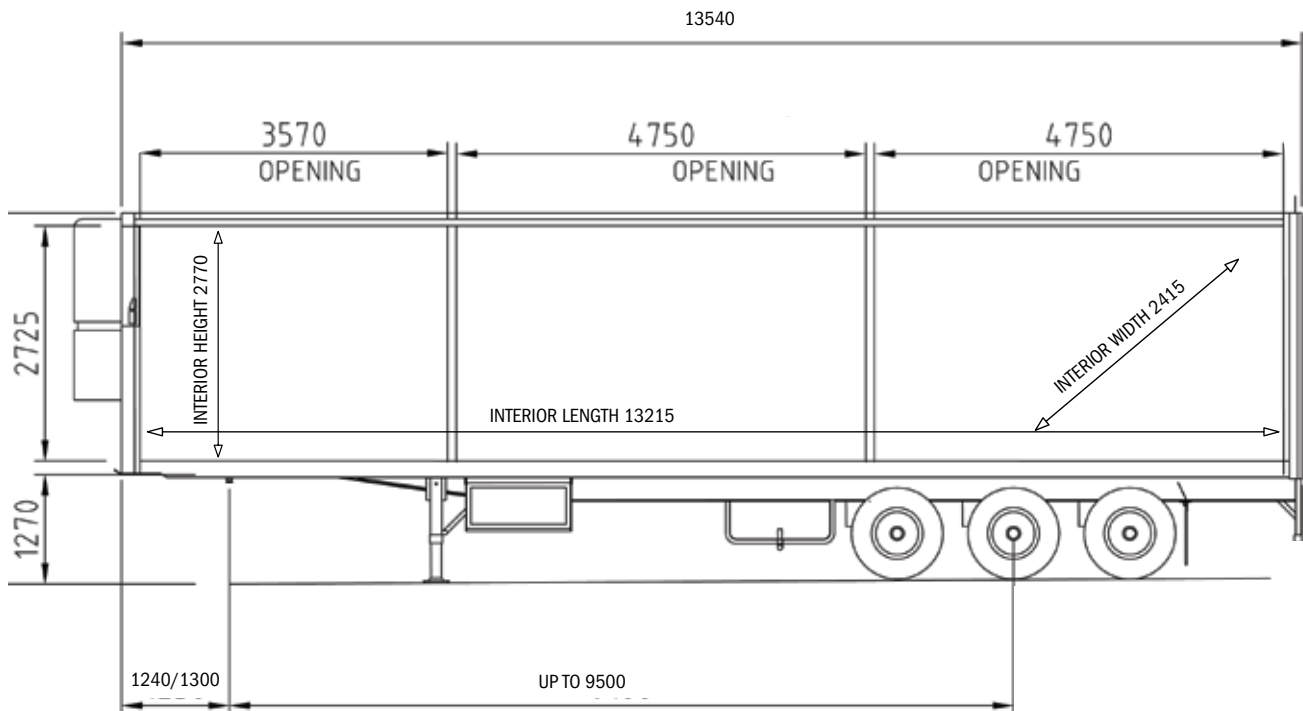

**Note:** interior width is nominal based on width between walls  
interior height based on t/table height of 1270mm  
22 Pallet unit illustrated - other sizes available

**Maxi-CUBE**

*Classic*

[www.maxicube.com.au](http://www.maxicube.com.au)

**MaxiTRANS Aust Pty Ltd**  
Victoria (03) 8368 1111  
Western Australia (03) 8368 1111

**SX Trailers**  
NSW (02) 9755 3333  
**Mildura Truck Centre**  
Sunraysia (03) 5051 2800

**CMV Trailer Sales**  
SA (08) 8139 4000  
**Western Diesel NT**  
NT (08) 8935 9100

**Freighter Maxi-CUBE Qld**  
QLD (07) 3277 5511  
**MaxiTRANS New Zealand**  
Auckland (09) 269 0712

Disclaimer: MaxiTRANS provides the information contained herein in good faith, based upon information current to date. MaxiTRANS reserves the right to change specifications without notice. However, MaxiTRANS accepts no liability, either direct or indirect, for any loss or consequential loss that may result from the application of this information. Purchasers must conduct their own enquiries to ensure that the products are suitable for their own particular purposes. Any comments made regarding products and construction are made on an informative basis, not as a recommendation. Some features shown may be optional.  
Classic™ and Maxi-CUBE are registered to the MaxiTRANS Group. MaxiTRANS Australia Pty Ltd. ABN 95 081 151 699.