

Maxi-CUBE

Classic

Lead Roll Back



The Maxi-CUBE Classic Lead Roll Back

Maxi-CUBE's Roll Back Lead Trailer is efficient and reliable, thanks to its proven and durable rack and pinion drive system. With a powerful high torque electro-hydraulic motor driving it and supported by ball bearing wheels, the Maxi-CUBE Roll Back moves smoothly and has no chains or cables to break. It is powered by a dedicated low maintenance battery that is charged from the refrigeration plant.

Maxi-CUBE Roll Back bodies make unloading a breeze and work time after time.

Some Maxi-CUBE Options to suit your needs

- Disc brakes
- Multi zone temperature control systems
- One-piece folding partition
- Maxi-Grip Floor system / Flat aluminium floor
- Versapan (patented) – a combination of meat van, double loader and conventional pantec
- Maxi-CUBE double loader system
- Rear roller doors
- Side doors

*Photo for illustrative purposes only.

Classic Lead Roll Back Specifications

(Nominal and Typical)

Dimensions

Body Length	7430mm
Overall height	4300mm
Skidplate Height	1270mm
Kingpin Location	1450mm from front
Suspension Location	7950mm from kingpin

Body Specifications dependant on model ordered

Deck

Chequerplate steel deck standard over chassis rails behind body

Frame

Bumper	Square
Skidplate	8mm with 50mm bolt-in kingpin
Rear Turntable	50mm weld-on. Non stabilized
Roll Back Body	DC electric/hydraulic motor drive

Underbody

Toolbox	1 standard. Kerbside
Tyre Carrier	1 standard. Rigid 2 wheel galvanised

Electrical

Voltage	12 or 24
Lamps	Multi-volt LED to ADR 13
Interior	2-roof mounted
Couplings	Standard and heavy duty 7 pin

Landing Gear

Rocker Foot	2 speed
-------------	---------

Paint

Exterior	White gelcoat. Interior - Blue gelcoat
Body Underside	Galvanised
Skel	Painted

Mudguards

Plastic with sprayguard flaps at rear of suspension

Suspension

Tri-axle air bag. Raise / Lower valve

Wheels

10 stud steel, dual rim

Brakes

420 x 178mm (16.5" x 7") S' Cam to A.D.R. 38.HXS Linings

PBR male and female couplings at front and rear

Rear couplings on hoses

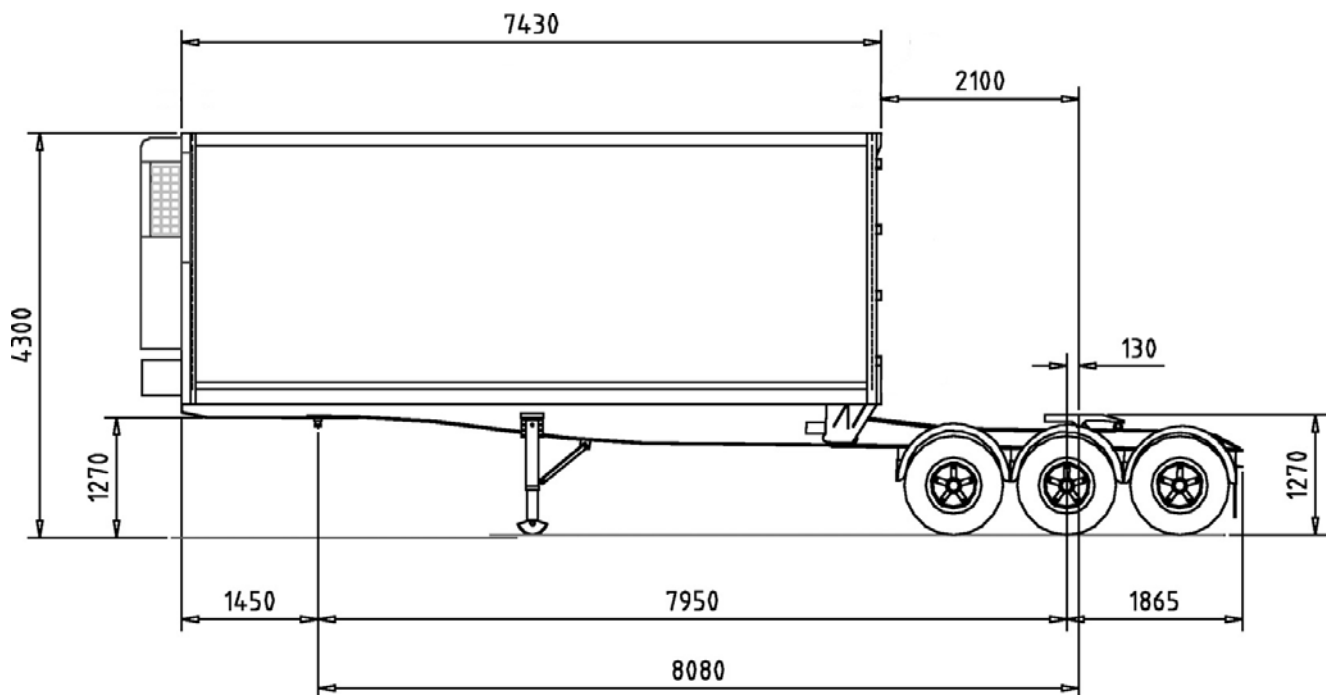

Note: Dimensions shown for a refrigerated unit.



www.maxicube.com.au

MaxiTRANS Aust Pty Ltd
Victoria (03) 8368 1111
Western Australia (03) 8368 1111

SX Trailers
NSW (02) 9755 3333
Mildura Truck Centre
Sunraysia (03) 5051 2800

CMV Trailer Sales
SA (08) 8139 4000
Western Diesel NT
NT (08) 8935 9100

Freighter Maxi-CUBE Qld
QLD (07) 3277 5511
MaxiTRANS New Zealand
Auckland (09) 269 0712

Disclaimer: MaxiTRANS provides the information contained herein in good faith, based upon information current to date. MaxiTRANS reserves the right to change specifications without notice. However, MaxiTRANS accepts no liability, either direct or indirect, for any loss or consequential loss that may result from the application of this information. Purchasers must conduct their own enquiries to ensure that the products are suitable for their own particular purposes. Any comments made regarding products and construction are made on an informative basis, not as a recommendation. Some features shown may be optional.
Classic™ and Maxi-CUBE are registered to the MaxiTRANS Group. MaxiTRANS Australia Pty Ltd. ABN 95 081 151 699.