

# Maxi-CUBE

## Classic Freezer

Rating -22°C\*



## The Maxi-CUBE Classic

For 30 years, Maxi-CUBE has lead the Australian temperature controlled transport market in product innovation, providing its customers with reliable, high payload, high volume, thermally efficient vans that deliver profits to their owners.

### Some Maxi-CUBE Options to suit your needs

- 14.9m unit available where state legislation permits
- Various lengths and heights available to order
- Disc brakes
- Multi zone temperature control systems
- One-piece folding partition
- Flat fibreglass floor/anti-slip floor/flat aluminium floor
- Fibreglass rear infill panel
- Versapan (patented) - a combination of meat van, double loader and conventional pantec
- Belly lockers (dry freight or temperature controlled)
- Maxi-CUBE double loader system
- Roller doors
- Side doors

\*Actual thermal performance will depend on ambient conditions and the refrigeration plant fitted.  
Photo for illustrative purposes only.

# Classic Freezer Specifications

(Nominal and Typical)

## Dimensions

Length	(22/24 pallet) 13540mm / 14500mm (45/48ft)
Overall Height	4300mm
Skidplate Height	1270mm
Kingpin Location	1240mm / 1300mm from front
Suspension Location	Up to 9500mm from kingpin

## Body

Roof	125mm insulation foam faced with high gloss fibreglass
Side Walls	25mm fibreglass/foam panels. Polished aluminium body rails.
Floor	Forklift rated aluminium airflow. 95mm insulation
Front Wall	Extruded aluminium frame. 100mm insulation
Rear Doors	FRP/foam panels & anti-rack double lock rods
Rub Strip	External - aluminium extrusion
Scuff Band	Internal - integrated fibreglass composite
Interior Joints	Fully sealed
Rear Frame	Fabricated galvanised steel

## Refrigeration

Plant	Provision for refrigeration plant
Return Air Bulkhead	Fibreglass Panel

## Frame

Crossmembers	Steel
Bumper	100mm square steel
Skidplate	8mm with 50mm bolt-in kingpin

## Brakes

S' Cam	to A.D.R. 38.
PBR	male and female couplings at front.

## Underbody

Tyre Carrier	1 Standard. Rigid 2 wheel Galvanised
Tool Box	Standard

## Electrical

Voltage	Multi-volt to A.D.R. 13 (exterior lighting)
Lamps	LED Multi-volt
Interior	3 - roof mounted (12 volt)
Twin electrical plugs at front	

## Landing Gear

Rocker Foot	2 speed
-------------	---------

## Paint

Exterior	White gelcoat. Interior - Blue gelcoat.
Underside	Silver or galvanised.

## Mudguards

Extruded aluminium splashguards with flaps fitted to rear of suspension group.	
--	--

## Suspension

Tri-axle	air bag
----------	---------

## Axles

Maxus	10 stud
-------	---------

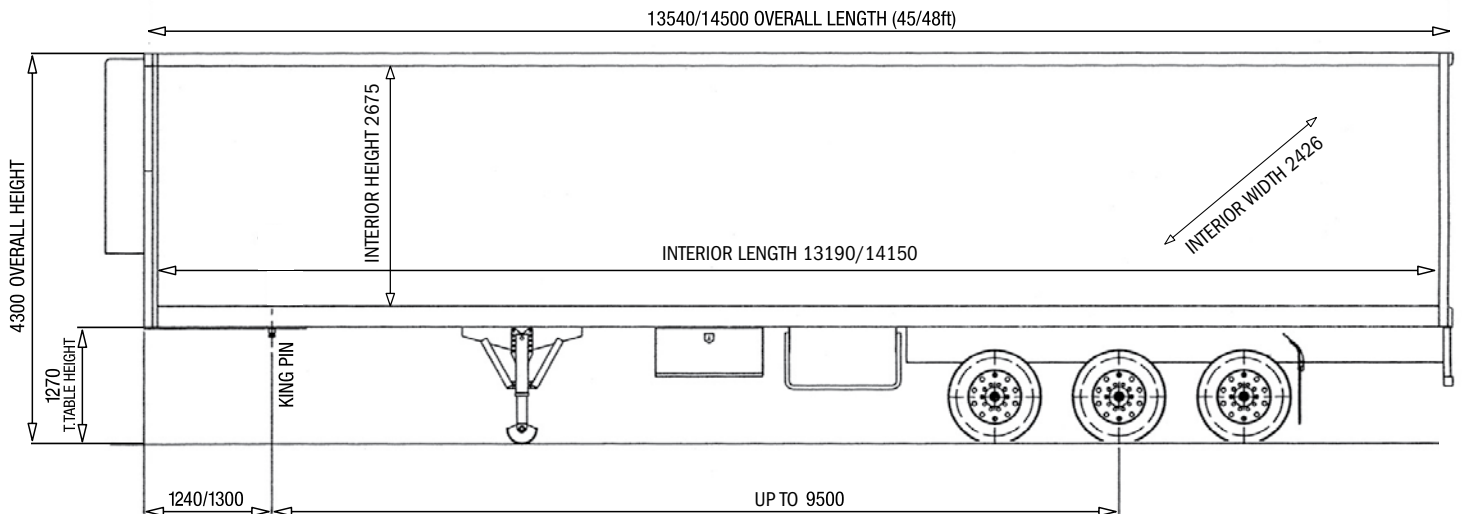

**Note:** interior width is nominal based on width between walls  
interior length based on Thermo-King SB310 and Carrier equivalent  
interior height based on t/table height of 1270mm

**Maxi-CUBE**

*Classic*

[www.maxicube.com.au](http://www.maxicube.com.au)

**MaxiTRANS Aust Pty Ltd**  
Victoria (03) 8368 1111  
Western Australia (03) 8368 1111

**SX Trailers**  
NSW (02) 9755 3333  
**Mildura Truck Centre**  
Sunraysia (03) 5051 2800

**CMV Trailer Sales**  
SA (08) 8139 4000  
**Western Diesel NT**  
NT (08) 8935 9100

**Freighter Maxi-CUBE Qld**  
QLD (07) 3277 5511  
**MaxiTRANS New Zealand**  
Auckland (09) 269 0712

Disclaimer: MaxiTRANS provides the information contained herein in good faith, based upon information current to date. MaxiTRANS reserves the right to change specifications without notice. However, MaxiTRANS accepts no liability, either direct or indirect, for any loss or consequential loss that may result from the application of this information. Purchasers must conduct their own enquiries to ensure that the products are suitable for their own particular purposes. Any comments made regarding products and construction are made on an informative basis, not as a recommendation. Some features shown may be optional.  
Classic™ and Maxi-CUBE are registered to the MaxiTRANS Group. MaxiTRANS Australia Pty Ltd. ABN 95 081 151 699.